

# ONETOUCH

## Verio Reflect™

Blood Glucose Monitoring System



## Owner's Booklet

Instructions for Use

Your OneTouch Verio Reflect™ Meter includes a range of new colored features, which may help with your diabetes management.

## Results, Meal and Event tagging



## Blood Sugar Mentor™ Messages

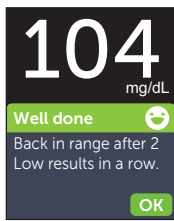
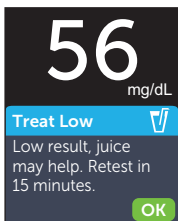
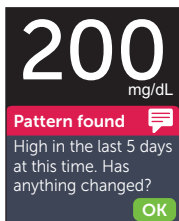

## Awards, Summaries and Trend 90

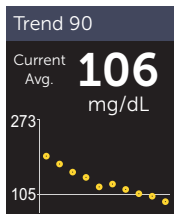
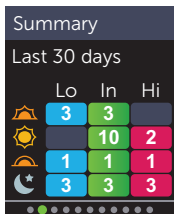
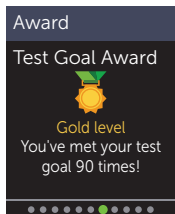

Please refer to this Owner's Booklet for further details on each of the new features

**ONETOUCH**  
**Verio Reflect™**  
Blood Glucose Monitoring System  
**Owner's Booklet**

## **Thanks for choosing OneTouch®!**

The OneTouch Verio Reflect™ Blood Glucose Monitoring System is one of the latest product innovations from OneTouch®.

Your OneTouch Verio Reflect™ Meter is designed to connect (sync) with a variety of compatible wireless devices running software applications. By connecting your meter with the OneTouch Reveal® App you can review and graph your results, set Daily Test Goals, see Blood Sugar Mentor™ Messages and help identify patterns. Meter results and other tracked data are sent to the compatible devices either through BLUETOOTH® (wireless) or USB cable connection. Visit [www.OneTouch.com](http://www.OneTouch.com) for more information about the OneTouch Reveal® App.



Every OneTouch® Meter is designed to help you test your blood glucose and manage your diabetes.

This Owner's Booklet offers a complete explanation of how to use your new meter and testing supplies. It reviews the do's and don'ts of testing your blood glucose level. Please keep your Owner's Booklet in a safe place; you may want to refer to it in the future.

We hope OneTouch® products and services will continue to be a part of your life.

# Meter symbols and icons

## Range Indicator icons and Color Bar



Result below target range



Result at low end of target range



Result near middle of target range



Result in middle of target range



Result near middle of target range



Result at high end of target range



Result above target range



Result in range (text)

## Meal and Event tags



Before Meal tag



After Meal tag



Event tag



Carbs Event tag



Stress Event tag



Illness Event tag



Medication Event tag



Exercise Event tag

## Patterns, Test Tracker, and Awards



Low Pattern Message (blue icon)



High Pattern Message (red icon)



Daily Test Goal met



Daily Test Goal not met



Gold award



Silver award



Bronze award

## Main Menu and Settings Menu icons



Summary



Results Log



Trend 90



Settings Menu



Range Indicator icons as emoji



Range Indicator icons as text

## Other meter icons



BLUETOOTH® feature on



Syncing



Control solution result



Low battery



Screen navigation progress dots

## Other symbols and icons



Cautions and Warnings: Refer to the Owner's Booklet and inserts that came with your system for safety-related information.



Direct current

## Before you begin

Before using this product to test your blood glucose, carefully read this Owner's Booklet, and the inserts that come with the OneTouch Verio<sup>®</sup> Test Strips, OneTouch Verio<sup>®</sup> Control Solutions and the OneTouch<sup>®</sup> Delica<sup>®</sup> Plus Lancing Device.

## **IMPORTANT SAFETY INSTRUCTIONS:**

- This meter and lancing device are for single patient use only. **Do Not** share them with anyone else, including family members! **Do Not** use on multiple patients!
- After use and exposure to blood, all parts of this kit are considered biohazardous. A used kit may potentially transmit infectious diseases even after you have performed cleaning and disinfection.

For more information see: *FDA Public Health Notification: "Use of Fingertick Devices on More than One Person Poses Risk for Transmitting Bloodborne Pathogens: Initial Communication 2010"* <http://wayback.archive-it.org/7993/20170111013014/http://www.fda.gov/MedicalDevices/Safety/AlertsandNotices/ucm224025.htm>

CDC website on "Infection Prevention during Blood Glucose Monitoring and Insulin Administration"  
<http://www.cdc.gov/injectionsafety/blood-glucose-monitoring.html>

## **Intended use**

The OneTouch Verio Reflect™ Blood Glucose Monitoring System is composed of the OneTouch Verio Reflect™ Meter and OneTouch Verio® Test Strips. The OneTouch Verio Reflect™ Blood Glucose Monitoring System is intended to be used for the quantitative measurement of glucose (sugar) in fresh capillary whole blood samples drawn from the fingertips. The OneTouch Verio Reflect™ Blood Glucose Monitoring System is intended for self-testing outside the body (*in vitro* diagnostic use), by individuals with diabetes at home as an aid to monitor the effectiveness of diabetes control. The system is intended to be used by a single person and should not be shared. The system should not be used for the diagnosis of, or screening for diabetes or for neonatal use.



**⚠️WARNING:** This device is not intended for use in healthcare or assisted-use settings such as hospitals, physician offices, or long-term care facilities because it has not been cleared by the FDA for use in these settings, including for routine assisted testing or as part of glycemic control procedures. Use of this device on multiple patients may lead to transmission of Human Immunodeficiency Virus (HIV), Hepatitis C Virus (HCV), Hepatitis B Virus (HBV), or other bloodborne pathogens.

## Limitations

The OneTouch Verio Reflect™ Blood Glucose Monitoring System is intended to be used by a single patient and should not be shared. The OneTouch Verio Reflect™ System is not to be used for the diagnosis or screening of diabetes or for neonatal use. The OneTouch Verio Reflect™ System is not for use on critically ill patients, patients in shock, severely dehydrated patients or hyperosmolar patients (with or without ketosis). **Do Not** use the OneTouch Verio Reflect™ System for alternate site testing (AST).

OneTouch Verio® Test Strips should not be used at altitudes above 10,000 feet as there may be an adverse effect on test results. A hematocrit (percentage of your blood that is red blood cells) that is either very high (above 60%) or very low (below 20%) can cause false results. Talk to your healthcare professional if you don't know your hematocrit level. The OneTouch Verio Reflect™ Blood Glucose Monitoring System should not be used within 24 hours of receiving a D-xylose absorption test as it may cause inaccurately high glucose results with your meter. **Do Not** use the OneTouch Verio Reflect™ Blood Glucose Monitoring System if you are being treated for organophosphate poisoning with Pralidoxime (PAM) as it may cause inaccurate glucose results with your meter.

## Test principle

Glucose in the blood sample mixes with the enzyme FAD-GDH (see page 160) in the test strip and a small electric current is produced. The strength of this current calculates your blood glucose level. It then displays the blood glucose result and stores it in the meter memory.

Use only OneTouch Verio® Control Solutions and Test Strips with the OneTouch Verio Reflect™ Meter. Use of OneTouch Verio® Test Strips with meters for which they are not intended may yield inaccurate results.

## **BLUETOOTH® wireless technology**

BLUETOOTH® wireless technology is used by some smartphones and many other devices. Your OneTouch Verio Reflect™ Meter uses BLUETOOTH® wireless technology to pair and to send your glucose results to compatible wireless devices.

The OneTouch Verio Reflect™ Meter is designed to work with the OneTouch Reveal® Mobile App.

Visit [www.OneTouch.com](http://www.OneTouch.com) for information on which wireless devices are compatible with your OneTouch Verio Reflect™ Meter, and where/how to download the OneTouch Reveal® Mobile App.

When using the OneTouch Verio Reflect™ System, we suggest you pair your OneTouch Verio Reflect™ Meter with a compatible wireless device and track your results. See page 112 for pairing instructions.

Changes or modifications not expressly approved by the party responsible for compliance could void the user's authority to operate the equipment.

This device complies with Part 15 of the FCC Rules. Operation is subject to the following two conditions: (1) this device may not cause harmful interference and (2) this device must accept any interference received, including interference that may cause undesired operation.

**NOTE:** This equipment has been tested and found to comply with the limits for a Class B digital device, pursuant to part 15 of the FCC Rules. These limits are designed to provide reasonable protection against harmful interference in a residential installation. This equipment generates, uses and can radiate radio frequency energy and, if not installed and used in accordance with the instructions, may cause harmful interference to radio communications. However, there is no guarantee that interference will not occur in a particular installation. If this equipment does cause harmful interference to radio or television reception, which can be determined by turning the equipment off and on, the user is encouraged to try to correct the interference by one or more of the following measures:

- Reorient or relocate the receiving antenna.
- Increase the separation between the equipment and receiver.

- Connect the equipment into an outlet on a circuit different from that to which the receiver is connected.
- Consult the dealer or an experienced radio/TV technician for help.

These guidelines help ensure that your meter will not affect the operation of other nearby electronic devices. Additionally, other electronic devices should not affect the use of your meter.

If you experience meter interference problems, try moving your meter away from the source of the interference. You can also move the electronic device or its antenna to another location to solve the problem.

** WARNING:** The BLUETOOTH® feature on your meter sends test results to your compatible wireless device. To prevent other people's results from being sent to your compatible wireless device, **Do Not** let anyone else use your meter to test their blood glucose. This meter is for single patient use only.

**⚠️WARNING:** In locations where cell phone use is not permitted, such as hospitals, some healthcare professional offices and airplanes, you should turn the BLUETOOTH® feature off. See page 108 for more information.

**Do Not** leave your meter unattended or in a public place so that others may change your personal parameters or make physical connections to it.

The meter has been designed defensively to ward off malicious intent and has been tested accordingly.

## **BLUETOOTH® trademark**

The BLUETOOTH® word mark and logos are registered trademarks owned by Bluetooth SIG, Inc. and any use of such marks by LifeScan Scotland Ltd. is under license. Other trademarks and trade names are those of their respective owners.

# Table of Contents

<b>1</b>	<b>Getting to know your system .....</b>	<b>18</b>
<b>2</b>	<b>Setting up your system.....</b>	<b>28</b>
<b>3</b>	<b>Taking a test.....</b>	<b>42</b>
	Testing your blood glucose.....	42
	Testing with control solution .....	68
<b>4</b>	<b>Tagging results .....</b>	<b>78</b>
<b>5</b>	<b>Understanding Messages .....</b>	<b>84</b>
<b>6</b>	<b>Summary, Results Log and Trend 90.....</b>	<b>96</b>
<b>7</b>	<b>Syncing your meter.....</b>	<b>108</b>
<b>8</b>	<b>Adjusting meter settings .....</b>	<b>120</b>
<b>9</b>	<b>Caring for your system .....</b>	<b>134</b>
<b>10</b>	<b>Batteries.....</b>	<b>142</b>
<b>11</b>	<b>Troubleshooting .....</b>	<b>146</b>
<b>12</b>	<b>System information .....</b>	<b>156</b>
<b>13</b>	<b>Index .....</b>	<b>168</b>

# 1 Getting to know your system

## Your OneTouch Verio Reflect™ Blood Glucose Monitoring System

Included with your kit:



OneTouch Verio Reflect™  
Meter (2 CR2032 lithium  
coin cell batteries  
included)



Lancing device



Lancets



OneTouch Verio®  
Test Strips\*



**NOTE:** If any item is missing or defective in your kit, contact Customer Service. Contact information for Customer Service is listed at the end of this Owner's Booklet.

**NOTE:** If another type of lancing device was included, see the separate instructions for that lancing device.

## 1 Getting to know your system

### Available separately:

Items pictured below are required, but may not be included in your kit:

They are sold separately. Refer to your meter carton for a list of included items.



OneTouch Verio® Level 3  
Control Solution\*  
(vial with blue cap)



OneTouch Verio® Level 4  
Control Solution\*  
(vial with red cap)



OneTouch Verio®  
Test Strips\*

\*OneTouch Verio® Control Solution and Test Strips are available separately. For availability of test strips and control solution, contact Customer Service or ask your pharmacist or healthcare professional.

You can use either OneTouch Verio® Level 3 Control Solution or OneTouch Verio® Level 4 Control Solution with your OneTouch Verio Reflect™ Meter.

**⚠️WARNING:** Keep the meter and testing supplies away from young children. Small items such as the battery door, batteries, test strips, lancets, protective covers on the lancets, and control solution vial cap are choking hazards. **Do Not** ingest or swallow any items.

## 1 Getting to know your system

### Getting to know your OneTouch Verio Reflect™ Blood Glucose Monitoring System

#### Meter



<b>1</b>	<b>Test strip port</b> Insert test strip here to turn meter on
<b>2</b>	<b>Battery icon</b> Appears only when batteries are low
<b>3</b>	<b>mg/dL</b> is the pre-set unit of measure and cannot be changed*
<b>4</b>	<b>Micro USB data port</b> Connect to download to a computer
<b>5</b>	<b>OK button</b> <ul style="list-style-type: none"><li>• Turns meter on/off (press and hold)</li><li>• Confirms menu selections (press and release)</li></ul>
<b>6</b>	<b>Back button</b> <ul style="list-style-type: none"><li>• Go back to the previous screen (press and release)</li><li>• May be used to change a Meal tag or add an Event tag</li></ul>
<b>7</b>	<b>Up and down buttons</b> <ul style="list-style-type: none"><li>• Highlight selection (press and release)</li><li>• Increase scrolling speed (press and hold)</li></ul>
<b>8</b>	<b>Color Bar</b>
<b>9</b>	<b>Range Indicator icon</b>
<b>10</b>	<b>Test Tracker icons</b>

## 1 Getting to know your system

**⚠️WARNING:** \*Confirm that the unit of measure mg/dL is displayed. If your display shows mmol/L rather than mg/dL, stop using the meter and contact Customer Service.

### Getting to know your OneTouch Verio® Test Strip

Test strip



11	<b>Channel to apply sample</b>
12	<b>Silver prongs</b> Insert into test strip port (1)

## Features overview

The OneTouch Verio Reflect™ Meter is equipped with features designed to help you manage your blood glucose in a variety of ways. We hope you will take advantage of these features and make them part of your diabetes management routine.

### **Blood Sugar Mentor™ Messages**

Blood Sugar Mentor™ Messages provide insight on how you're doing and diabetes management guidance, including educational and motivational messages based on your current and previous glucose results and other tracked data. When you receive your blood glucose result, the meter may display Mentor Tips (guidance), Pattern Messages (insight) or Awards (encouragement).

## 1 Getting to know your system

### Examples of Blood Sugar Mentor™ Messages

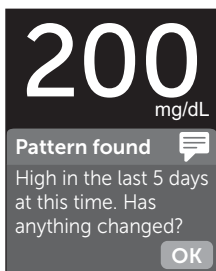

**200**  
mg/dL

**Pattern found** 

High in the last 5 days at this time. Has anything changed?

**OK**

**Insight**



**56**  
mg/dL

**Treat Low** 

Low result, juice may help. Retest in 15 minutes.

**OK**

**Guidance**

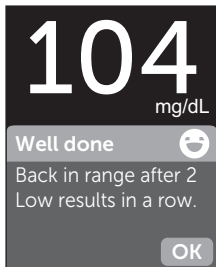

**104**  
mg/dL

**Well done** 

Back in range after 2 Low results in a row.

**OK**

**Encouragement**



### **ColorSure® Dynamic Range Indicator**

The ColorSure® Dynamic Range Indicator instantly lets you know if your current result is below (blue), within (green) or above (red) your range limits. It also shows when your result is near the low or high end of your target range.

### **Test Tracker**

The Test Tracker lets you set the number of glucose tests you plan to take each day and automatically tracks progress towards achieving that goal.

### **Trend 90**

Trend 90 lets you set your blood glucose 90 Day Average Target and tracks progress towards that goal. The Trend 90 graph is automatically updated every 14 days and provides a view of how your overall glucose control is trending over time.

## 2 Setting up your system

### Setting up your meter

#### Turn your meter on

To turn your meter on, press and hold **OK** until the Welcome screen appears. Once the Welcome screen is displayed, release **OK**. You can also turn the meter on by inserting a test strip.

Every time you turn your meter on, a Welcome screen will appear for a few seconds. If the meter does not power on, check the batteries. See page 142.

#### **⚠ CAUTION:**

If you see any missing pixels within the Welcome screen, there may be a problem with the meter. Contact Customer Service. Contact information for Customer Service is listed at the end of this Owner's Booklet.

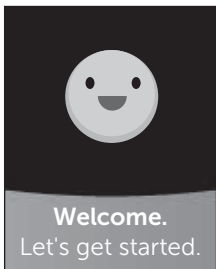

Example

**NOTE:** Whether you turn the meter on for the first time using  or a test strip, you will need to perform first time setup.

### **Use the display backlight for better visibility**

The backlight comes on automatically whenever the meter is turned on. After a few seconds of no activity, the backlight will dim. Pressing any button or inserting a test strip will turn the backlight back on.







### **First time setup**

Before using your meter for the first time, you will be prompted to set the language, time, date, range limits, Daily Test Goal, and 90 Day Average Target.



## 2 Setting up your system

### **NOTE:**

- You will not be able to perform a blood glucose test until you complete first time setup.
- Be sure to talk to your healthcare professional about setting the right range limits, Daily Test Goal, and 90 Day Average Target for you. When selecting or changing these settings, you should consider factors such as your lifestyle and diabetes therapy. Never make significant changes to your diabetes care plan without consulting your healthcare professional.
- It is important to select the settings with care to ensure the correct information is stored with your test results.

The meter comes pre-set to help you with first time setup. But if you need to edit a setting, press  or  to highlight **Edit** and press . You can then press  or  to change values. After making your selection, highlight **Save** and press  to confirm your selection and proceed to the next screen.

Pressing  returns you to the previous screen.

**1. Press  or  to highlight the language you want, then press  to select**

The meter will display a prompt giving the option to complete first time setup using the OneTouch Reveal® App. Visit [www.OneTouch.com](http://www.OneTouch.com) for more information about the OneTouch Reveal® App. If you do not want this option, highlight **No** and press  to continue first time setup using only the meter.



## 2 Setting up your system

Selecting **Yes** will prompt you to pair the meter with your compatible wireless device. See page 110. After pairing, the OneTouch Reveal® App will guide you through the process of first time setup. The remaining steps below will not be needed.

**NOTE:** The green progress dot will move from left to right as you navigate through the first time setup screens.

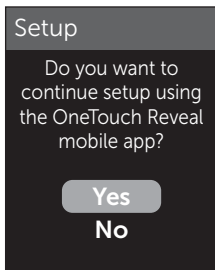

**2. Confirm the time, then press**  
**OK to save**

Selecting **Edit** will allow you to change the pre-set time.

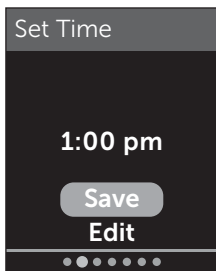
**3. Confirm the date, then press**  
**OK to save**

Selecting **Edit** will allow you to change the pre-set date.

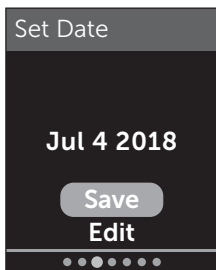

## 2 Setting up your system

### NOTE:

- The time and date format cannot be changed.
- Once every 6 months, and every time you change the batteries, a screen will prompt you to confirm the time and date set in the meter.

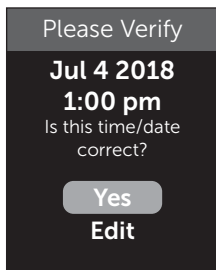

### Example

Selecting **Edit** will allow you to change the time and date. Once correct, select **Done**.

### 4. Confirm the Before Meal range limits, then press to save

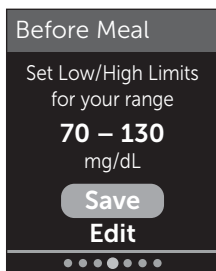

### Example

Selecting **Edit** will allow you to change the pre-set Before Meal range limits.



Your meter uses the Before Meal and After Meal range limits set in your meter to tell you when a test result is within, below or above your mealtime range limits. The mealtime range limits you set during first time setup will apply to all glucose results. They are used in the ColorSure® Dynamic Range Indicator feature, to detect Patterns and in the Summary. See page 59, page 85 and page 96 for more information.

### **Before Meal range limits**

pre-set low limit	70 mg/dL
pre-set high limit	130 mg/dL
low limit must be set within	60 mg/dL and 110 mg/dL
high limit must be set within	90 mg/dL and 300 mg/dL

## 2 Setting up your system

5. Confirm the After Meal range limits, then press  to save

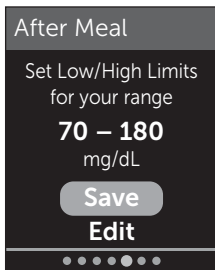

Example

Selecting **Edit** will allow you to change the pre-set After Meal range limits.

### After Meal range limits

pre-set low limit	70 mg/dL
pre-set high limit	180 mg/dL
low limit must be within	60 mg/dL and 110 mg/dL
high limit must be within	90 mg/dL and 300 mg/dL

## 6. Confirm the Test Tracker setting, then press to save

Selecting **Edit** will allow you to change the pre-set Daily Test Goal for the Test Tracker.

The Test Tracker lets you set the number of glucose tests you plan to take each day and automatically tracks progress towards achieving that goal.

The meter is pre-set with a Daily Test Goal of four tests per day. The maximum Daily Test Goal is eight. See page 128 for more information.

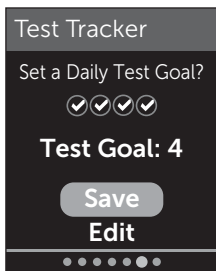

## 2 Setting up your system

### 7. Confirm the 90 Day Average Target, then press to save

Selecting **Edit** will allow you to change the pre-set 90 Day Average Target.

Trend 90 lets you set your blood glucose 90 Day Average Target and tracks progress towards that goal. The Trend 90 graph is automatically updated every 14 days and provides a view of how your overall glucose control is trending over time.

The meter is pre-set with a 90 Day Average Target of 155 mg/dL. The minimum 90 Day Average Target is 99 mg/dL and the maximum is 265 mg/dL. See page 105 for more information.

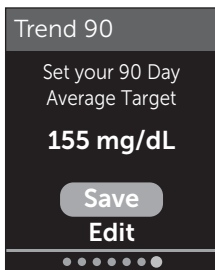

**Setup complete** appears on the screen. Your meter is ready for use.

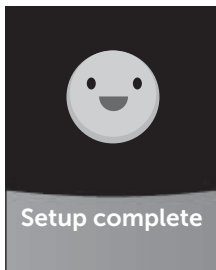



If the meter was turned on by inserting a test strip, the **Apply Blood** screen will appear. To perform a blood glucose test, see page 42.

**NOTE:** After first time setup, you can adjust your settings at any time. See page 120 for more information.

### **Understanding Basic Mode**

The meter comes with many features to help track diabetes management progress. Basic Mode will turn off these features if you prefer not to use the meter in this way.

## 2 Setting up your system

When Basic Mode is selected, the Test Tracker, Meal and Event tagging, Before and After Meal averages, Trend 90, Pattern Messages, Mentor Tips and Awards will be turned off. In Basic Mode, range limits are general and are not defined by mealtime. Range Indicator icons appear as text (for example, ) rather than as emoji (for example, )

For more information about turning Basic Mode on or off see page 127.

### Turning the meter off

There are three ways to turn your meter off:

- Press and hold  for several seconds until the meter turns off.
- Remove the test strip.
- Your meter will turn off by itself if left alone for two minutes.

This page left blank intentionally.

## **3** Taking a test

### **Testing your blood glucose**

#### **Preparing for a blood glucose test**

**NOTE:** Many people find it helpful to practice testing with control solution before testing with blood for the first time. See page 70.

#### **Have these things ready when you test:**

OneTouch Verio Reflect™ Meter

OneTouch Verio® Test Strips

Lancing device

Sterile lancets

#### **NOTE:**

- Use only OneTouch Verio® Test Strips.
- Unlike some blood glucose meters, no separate step to code your OneTouch Verio Reflect™ System is required.
- Testing must be done within operating temperature range (43-111°F) and 10-90% non-condensing relative humidity.
- Make sure your meter and test strips are about the same temperature before you test.



- Keep test strips in a cool, dry place between 41°F and 86°F and below 90% relative humidity. See page 134 for full storage instruction.
- **Do Not** test if there is condensation (water build-up) on your meter. Move your meter and test strips to a cool, dry spot and wait for the meter surface to dry before testing.
- **Do Not** open the test strip vial until you are ready to remove a test strip and perform a test. Use the test strip **immediately** after removing it from the vial.
- Tightly close the cap on the vial immediately after use to avoid contamination and damage.
- Store unused test strips only in their original vial.
- **Do Not** return the used test strip to the vial after performing a test.
- **Do Not** re-use a test strip that had blood, control solution, or any contaminants applied to it. Test strips are for single use only.
- With clean, dry hands, you may touch the test strip anywhere on its surface. **Do Not** bend, cut or modify the test strip in any way.

### 3 Taking a test

- When you first open a vial of test strips, record the discard date on the label. Refer to the test strip insert or vial label for instructions on determining the discard date.
- Comparing your blood glucose test results taken with this meter to your results taken from a different meter is not recommended. Results may differ between meters and are not a useful measure of whether your meter is working properly. To check your meter accuracy, you should periodically compare your meter results to those obtained from a lab. See page 156 for more information.

**IMPORTANT:** If another person assists you with testing, the meter should always be cleaned prior to use by that person. See page 134.

**⚠️ CAUTION:**

- **Do Not** use your test strips if your vial is damaged or left open. This could lead to error messages or inaccurate results. Contact Customer Service immediately if the test strip vial is damaged. Contact information for Customer Service is listed at the end of this Owner's Booklet.
- If you cannot test due to a problem with your testing supplies, contact your healthcare professional. Failure to test could delay treatment decisions and lead to a serious medical condition.
- The test strip vial contains drying agents that are harmful if inhaled or swallowed and may cause skin or eye irritation.
- **Do Not** use test strips after the expiration date (printed on the vial) or the discard date, whichever comes first, or your results may be inaccurate.

### 3 Taking a test

## Getting to know your OneTouch® Delica® Plus Lancing Device

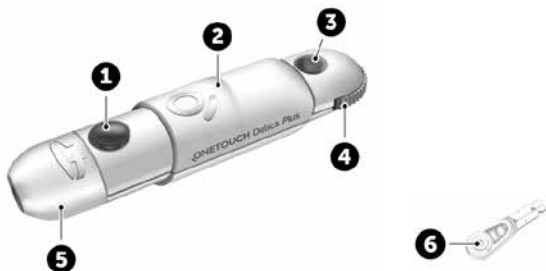

1	Release button
2	Slider control
3	Depth indicator
4	Depth wheel
5	Lancing device cap
6	Protective cover

**NOTE:**

- The OneTouch® Delica® Plus Lancing Device uses OneTouch® Delica® or OneTouch® Delica® Plus Lancets.
- If another type of lancing device was included, see the separate instructions for that lancing device.
- The OneTouch Verio Reflect™ Blood Glucose Monitoring System has not been evaluated for Alternate Site Testing (AST). Use only fingertips when testing with the system.
- The OneTouch® Delica® Plus Lancing System does not include the materials needed to perform Alternate Site Testing (AST). The OneTouch® Delica® Plus Lancing System should not be used on the forearm or palm with the OneTouch Verio Reflect™ Blood Glucose Monitoring System.

## 3 Taking a test

### Lancing precautions

#### CAUTION:

To reduce the chance of infection and disease spread by blood:

- Make sure to wash the sample site with soap and warm water, rinse and dry before sampling. Contaminants on the skin may affect results.
- The lancing device is intended for a single user. Never share a lancet or lancing device with anyone.
- Always use a new, sterile lancet each time you test.
- Always keep your meter and lancing device clean. (See page 134.)
- The meter and lancing device are for single patient use only. **Do Not** share them with anyone, including family members! **Do Not** use on multiple patients!
- After use and exposure to blood, all parts of this kit are considered biohazardous. A used kit may transmit infectious diseases even after you have performed cleaning and disinfection.
- **Do Not** use lancets after the expiration date printed on the lancet packaging.

## Preparing your lancing device

### 1. Remove the lancing device cap

Remove the cap by rotating it and then pulling it straight off the device.

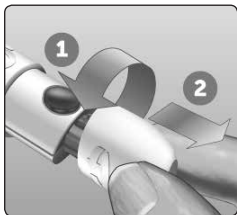

### 2. Insert a sterile lancet into the lancing device

Align the lancet as shown here, so that the lancet fits into the lancet holder. Push the lancet into the device until it snaps into place and is fully seated in the holder.

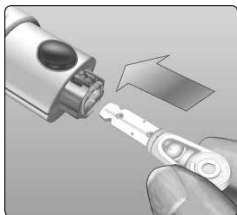

### 3 Taking a test

Twist the protective cover one full turn until it separates from the lancet. **Save the protective cover for lancet removal and disposal.** See page 65.

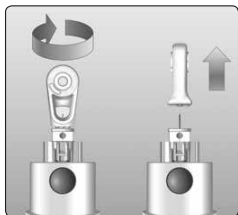

### 3. Replace the lancing device cap

Place the cap back onto the device; turn the cap or push the cap straight on to secure it.

Ensure the cap is aligned as shown in the image.

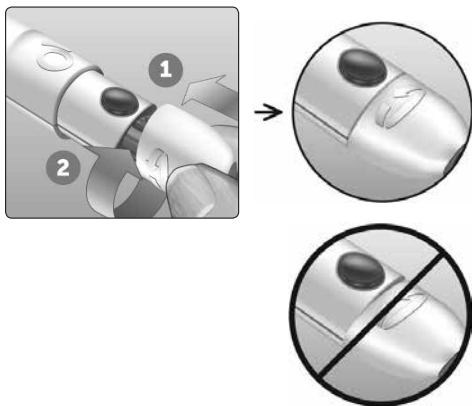



#### 4. Adjust the depth setting

The device has 13 puncture depth settings (each dot shown between numbers 1 to 7 on the Depth Wheel indicates an additional available depth setting). Adjust the depth by turning the depth wheel. Smaller numbers are for a shallower puncture and larger numbers for a deeper puncture.

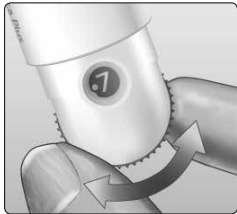

**NOTE:** Try a shallower setting first and increase the depth until you find the one deep enough to get a blood sample of the proper size.

#### 5. Cock the lancing device

Pull the slider back until it clicks. If it does not click, it may already have been cocked when you inserted the lancet.



### 3 Taking a test

#### Preparing the meter

##### 1. Insert a test strip to turn the meter on

Insert a test strip into the test strip port with the gold side of the test strip and the two silver prongs facing you.

Silver prongs



Test strip port

**NOTE:** No separate step to code the meter is required.

The **Apply Blood** screen appears on the display. You can now apply your blood sample to the test strip.



### **Sampling blood from the fingertip**

Choose a different puncture site each time you test. Repeated punctures in the same spot may cause soreness and calluses.

**Before testing, wash your hands and the sample site with warm, soapy water. Rinse and dry completely. Contaminants on the skin may affect results.**

### 3 Taking a test

#### 1. Puncture your finger

Hold the lancing device firmly against the side of your finger. Press the release button. Remove the lancing device from your finger.

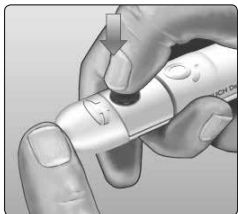

#### 2. Get a round drop of blood

Gently squeeze and/or massage your fingertip until a round drop of blood forms.

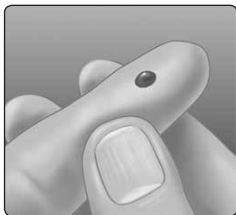

**NOTE:** If the blood smears or runs, **Do Not** use that sample. Dry the area and gently squeeze another drop of blood or puncture a new site.



## Applying blood and reading results

### Applying the sample

#### 1. Apply the sample to the test strip

Blood should be applied to the edge of the test strip. You can apply your sample to either side of the test strip channel.

Be sure to apply your sample immediately after you get a drop of blood.

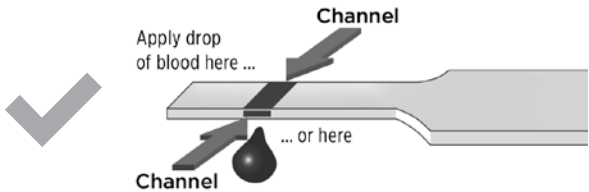

Blood should **not** be applied on the top of the test strip or to the end of the test strip.

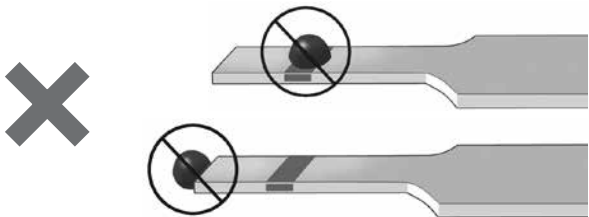

### 3 Taking a test

Holding the meter at a slight angle, guide the channel to the blood drop.

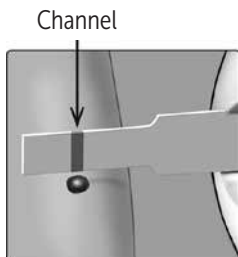

When it touches your sample, the test strip wicks blood into the channel.

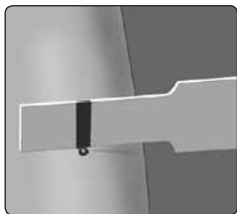

**2. Wait for the channel to fill completely**

The blood drop will be drawn into the narrow channel.  
The channel should fill completely.

The channel turns red and a result will be displayed after approximately 5 seconds.

### 3 Taking a test

#### **NOTE:**

- **Do Not** smear or scrape the sample with the test strip.
- **Do Not** press the test strip too firmly against the puncture site or the channel may be blocked from filling properly.
- **Do Not** apply more blood to the test strip after you have moved the drop of blood away.
- **Do Not** move the test strip in the meter during a test or you may get an error message or the meter may turn off.
- **Do Not** remove the test strip until the result is displayed or the meter will turn off.



## Viewing your result

### ColorSure® Dynamic Range Indicator

The OneTouch Verio Reflect™ Meter comes with a ColorSure® Dynamic Range Indicator feature that instantly lets you know if your current result is below (blue), within (green) or above (red) your range limits. It also shows when your result is near the low or high end of your target range. It does this by displaying your result with a Range Indicator icon pointing to a segment on the Color Bar based on the ranges you have set in the meter. The Range Indicator icon may be either an emoji (for example, 😊) or text (for example **In Range**). Use the Range Indicator icon and the segmented Color Bar together to see where your result falls within your range limits.

### 3 Taking a test



Low  
(Blue)

Example - below  
range result

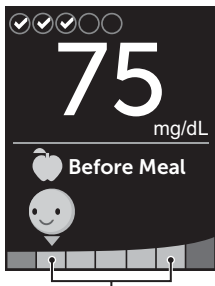

In Range  
(Green)

Example - low end  
of range result

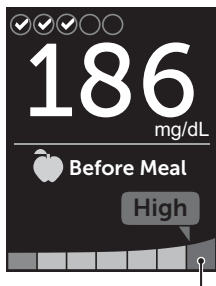

High  
(Red)

Example - above  
range result



If the Test Tracker is turned on, progress toward the Daily Test Goal will be indicated above the result. If the Test Tracker is turned off, the date and time will be shown above the result. The date and time are always recorded with each result and can be viewed in the Results Log. See page 102.

**⚠WARNING:** Confirm that the unit of measure mg/dL is displayed. If your display shows mmol/L rather than mg/dL, stop using the meter and contact Customer Service.

**⚠CAUTION:**

**Do Not** make immediate treatment decisions based on the ColorSure® Dynamic Range Indicator feature. Treatment decisions should be based on the numerical result and healthcare professional's recommendation and not solely on where your result falls within your range limits.

### 3 Taking a test

After the result screen appears, a Pattern Message, Mentor Tip or Award may be displayed. The Message can be dismissed by pressing . If you would like to bring the Message back, press  again. See page 84 for more information about Messages.

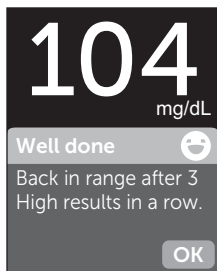

Example

A Before Meal tag will automatically be applied to your result. When you change a Before Meal tag to an After Meal tag, the Range Indicator icon may point to a different segment on the Color Bar. A new Message may appear. See page 78 for information on tagging results.

### Interpreting unexpected results

Refer to the following cautions when your results are higher or lower than what you expect.

**⚠️ CAUTION:****Low blood glucose results**

If your blood glucose result is below 70 mg/dL or is shown as **EXTREME LOW GLUCOSE**, (meaning the result is less than 20 mg/dL), it may mean hypoglycemia (low blood glucose).

This may require immediate treatment according to your healthcare professional's recommendations. Although this result could be due to a test error, it is safer to treat first, then do another test.

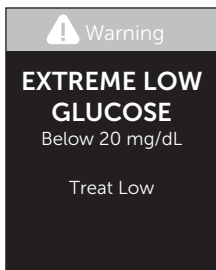
**⚠️ CAUTION:****Dehydration and low blood glucose results**

You may get false low blood glucose results if you are severely dehydrated. If you think you are severely dehydrated, contact your healthcare professional immediately.

### 3 Taking a test

#### CAUTION:

#### High blood glucose results

If your blood glucose result is above 180 mg/dL, it may mean hyperglycemia (high blood glucose) and you should consider re-testing. Talk to your healthcare professional if you are concerned about hyperglycemia.

**EXTREME HIGH GLUCOSE** is displayed when your blood glucose result is over 600 mg/dL. You may have severe hyperglycemia (very high blood glucose). Re-test your blood glucose level. If the result is **EXTREME HIGH GLUCOSE** again, this indicates a severe problem with your blood glucose control. Obtain and follow instructions from your healthcare professional immediately.

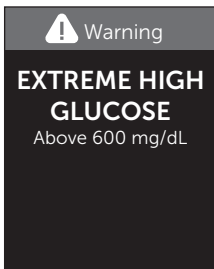

**⚠️ CAUTION:****Repeated unexpected blood glucose results**

- If you continue to get unexpected results, check your system with control solution. See page 70.
- If you are experiencing symptoms that are not consistent with your blood glucose results and you have followed all instructions in this Owner's Booklet, call your healthcare professional. Never ignore symptoms or make significant changes to your diabetes management program without speaking to your healthcare professional.

**Unusual red blood cell count**

A hematocrit (percentage of your blood that is red blood cells) that is either very high (above 60%) or very low (below 20%) can cause false results.

**Removing the used lancet**

**NOTE:** This lancing device has an ejection feature, so you do not have to pull out the used lancet.

### 3 Taking a test

#### 1. Remove the lancing device cap

Remove the cap by rotating it and then pulling it straight off the device.

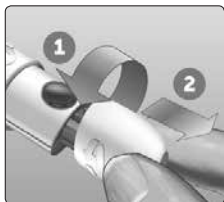

#### 2. Cover the exposed lancet tip

Before removing the lancet, place the lancet protective cover on a hard surface then push the lancet tip into the flat side of the disk.

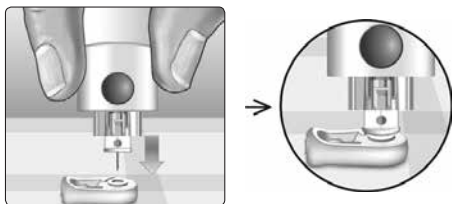



### 3. Eject the lancet

Holding the lancing device directed downwards, push the slider forward until the lancet comes out of the lancing device. If the lancet fails to eject properly, cock the device then push the slider control forward until the lancet comes out.



### 4. Replace the lancing device cap

Place the cap back onto the device; turn the cap or push the cap straight in to secure it.

Ensure the cap is aligned as shown in the image.

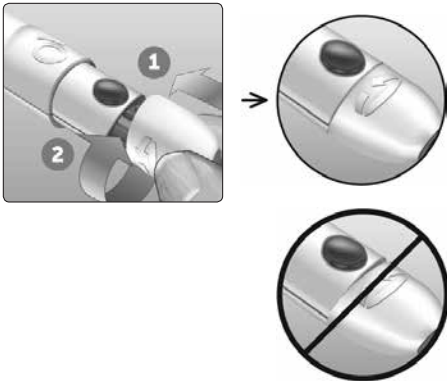

## 3 Taking a test

It is important to use a new lancet each time you obtain a blood sample. **Do Not** leave a lancet in the lancing device. This will help prevent infection and sore fingertips.

### Disposing of the used lancet and test strip

Discard the used lancet carefully after each use to avoid unintended lancet stick injuries. Used lancets and test strips may be considered biohazardous waste in your area. Be sure to follow your healthcare professional's recommendations or local regulations for proper disposal.

Wash hands thoroughly with soap and water after handling the meter, test strips, lancing device and cap.

### Testing with control solution

#### Control solution testing precautions

OneTouch Verio® Control Solution is used to check that the meter and test strips are working together properly and that the test is performing correctly. (Control solution is available separately.)

**NOTE:**

- Use only OneTouch Verio® Level 3 Control Solution or OneTouch Verio® Level 4 Control Solution with your OneTouch Verio Reflect™ Meter. Either level can be used to check your system.
- When you first open a new vial of control solution, record the discard date on the vial label. Refer to the control solution insert or vial label for instructions on determining the discard date.
- Tightly close the cap on the control solution vial immediately after use to avoid contamination or damage.

**⚠ CAUTION:**

- **Do Not** swallow or ingest control solution.
- **Do Not** apply control solution to the skin, eyes, ears or nose as it may cause irritation.
- **Do Not** use control solution after the expiration date (printed on the vial label) or the discard date, whichever comes first, or your results may be inaccurate.

## 3 Taking a test

### When to do a control solution test

- When you open a new vial of test strips.
- If you suspect that the meter or test strips are not working properly.
- If you have had repeated unexpected blood glucose readings.
- If you drop or damage the meter.

### Preparing your meter for a control solution test

#### 1. Press and hold to turn the meter on

Wait for the Main Menu to appear.

#### 2. Press or to highlight Settings, then press

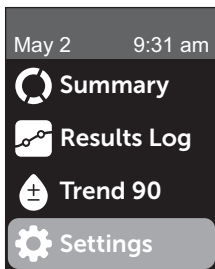

**3. Highlight Control Test, then press **

Wait for the **Insert Strip** screen to appear on the display.

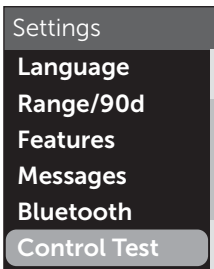

**4. Insert a test strip into the test strip port**



**5. Wait for the Apply Control Solution screen to appear on the display**



### 3 Taking a test

#### Preparing the control solution

1. Before removing the cap, shake the vial gently
2. Remove the vial cap and place it on a flat surface with the top of the cap pointing up
3. Squeeze the vial to discard the first drop

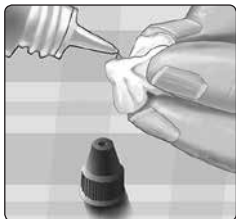

4. Wipe both the tip of the control solution vial and the top of the cap with a clean, damp tissue or cloth



**5. Squeeze a drop into the small well on the top of the cap or onto another clean, non-absorbent surface**



## **Applying the control solution**

**1. Hold the meter so that the side edge of the test strip is at a slight angle to the drop of control solution**



**2. Touch the channel on the side of the test strip to the control solution**

**3. Wait for the channel to fill completely**



## 3 Taking a test

### Viewing your control solution result

After the control solution is applied, your meter will display a progress screen for approximately 5 seconds. Your result is displayed along with the date, time, unit of measure, and  (for control solution).



Example

Control solution results are stored in the meter and can be seen when reviewing past results on the meter.

#### **CAUTION:**

Make sure you select **Control Test** from the Settings Menu before you begin a control solution test. Follow the steps beginning on page page 70. If  does not appear on the screen, this result will be included in your averages and your averages will change too. Repeat the test with a new test strip. If the problem persists, contact Customer Service. Contact information for Customer Service is listed at the end of this Owner's Booklet.



## Checking if the result is in range

Each vial of test strips has both OneTouch Verio® Level 3 Control Solution and OneTouch Verio® Level 4 Control Solution ranges printed on its label. Compare the result displayed on the meter to either the OneTouch Verio® Level 3 Control Solution or OneTouch Verio® Level 4 Control Solution range printed **on the test strip vial**, depending on the type of control solution you used.



### Example range

OneTouch Verio® Level 3  
Control Solution Control  
Range 102-138 mg/dL  
OneTouch Verio® Level 4  
Control Solution Control  
Range 298-403 mg/dL

### **⚠ CAUTION:**

The range printed on the test strip vial is for control solution tests only **and is not a recommended range for your blood glucose level.**

### **3** Taking a test

#### **Causes of out-of-range results**

Out-of-range results may be due to:

- Not following the instructions for performing a control solution test.
- Control solution is contaminated, expired, or past its discard date.
- Test strip or test strip vial is damaged, expired, or past its discard date.
- Meter, test strips and/or control solution were not all at the same temperature when the control solution test was performed.
- A problem with the meter.
- Dirt or contamination in the small well on the top of the control solution cap.

**⚠️ CAUTION:**

If you continue to get control solution results that fall outside the range printed on the test strip vial, **Do Not** use the meter, test strips, or control solution. Contact Customer Service. Contact information for Customer Service is listed at the end of this Owner's Booklet.

**Cleaning the control solution cap**

**Clean the top of the control solution cap with a clean, damp tissue or cloth.**

## 4 Tagging results

### Adding Meal and Event tags

Your OneTouch Verio Reflect™ Meter allows you to attach a Before Meal (🍏) or After Meal (🍷) tag to your current blood glucose result. It is important to understand the link between blood glucose levels and food. When you tag your test results with Meal tags, you add information about food to your results. Your meter uses this information in a variety of ways and displays Pattern Messages, Mentor Tips and Awards. Talk to your healthcare professional to see how Meal tags may help you manage your diabetes. Consider the following guidelines when Meal tagging.

- A Before Meal blood glucose test is taken just before the start of your meal.
- An After Meal blood glucose test is typically taken one to two hours after the start of your meal.
- A blood glucose test taken while fasting should be tagged as Before Meal.

In addition to Meal tagging, your OneTouch Verio Reflect™ Meter includes an Event tagging feature. Event tagging adds information about your health and lifestyle events to your blood glucose results. Your meter will review your past results and display Messages associated with tagged results when certain conditions are met. See page 4 for Event tag icons and their meanings.

### **1. View the current blood glucose result on the display**

The result will automatically receive a Before Meal tag and no Event tag.

### **2. If a Message appears, press to clear the Message**

## 4 Tagging results

3. To change to an After Meal tag, press  then highlight After Meal and press 

**NOTE:** The Range Indicator icon displayed with the result uses Before and After Meal ranges. When you change a Before Meal tag to an After Meal tag, the Range Indicator icon may point to a different segment on the Color Bar. A new Message may appear.



4. To add an Event tag to your result, press 

5. Press  or  to highlight  Event Tag, then press 

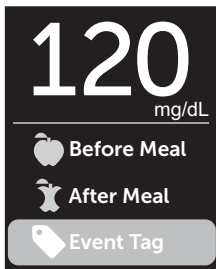

6. Press  or  to highlight an Event tag, then press 

You may add more than one Event tag to a result.

A  notes that an Event tag has been added.



## 4 Tagging results

7. When you have finished selecting Event tags, highlight Done and press 

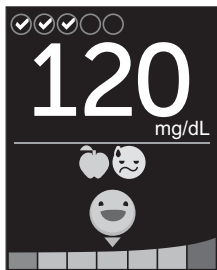

Example

The result will be displayed with the tags. Pressing and holding  will allow you to edit the tags.

**NOTE:** Use care when adding tags to blood glucose results. When you leave the result screen, the tags and result are stored in the Results Log and **cannot** be changed. Incorrect Meal tagging can cause the meter to identify inaccurate Before and After Meal averages and Patterns. Incorrect Event tagging can cause the meter to display incorrect Messages.



This page left blank intentionally.

## 5 Understanding Messages

### Blood Sugar Mentor™ Messages overview

The OneTouch Verio Reflect™ Meter reviews your past test results and may display Mentor Tips (guidance), Pattern Messages (insight) or Awards (encouragement). The meter will show you the most appropriate Message if more than one is applicable to your result.

1. **Mentor Tips** appear when your results are consistently in range or are currently trending low or high.
2. **Pattern Messages** appear when the meter identifies a pattern of glucose results that fall outside the high and low range limits you set in the meter.
3. **Awards** are earned when certain Award criteria are met, such as meeting the Daily Test Goal or tagging results.

Pressing  will dismiss Messages.

## Understanding Pattern Messages

Low and High Pattern Messages appear when the meter identifies a Pattern of glucose results that fall outside the low and high mealtime range limits set in your meter.

Every time you test your blood glucose, your OneTouch Verio Reflect™ Meter searches for any new Patterns that have developed over the past 5 days. Patterns are identified by finding results below or above the low and high mealtime range limits set in your meter, and cross referencing with the time of day the tests were taken. For a set of results to form a Pattern, the results must be within the same 3-hour time period over the past 5 days.

When a Pattern is identified, a Pattern message icon () appears below your result. A Pattern Message will be displayed after the result screen. Inaccurate results may cause Pattern Messages to appear.

Once a result is used in a Pattern, it will not be used again in future Pattern Messages.

## 5 Understanding Messages

### Reviewing results that create Patterns

There are two ways you can review the individual results that combine to create a Low or High Pattern.

To view a Low or High Pattern message after a test, press .



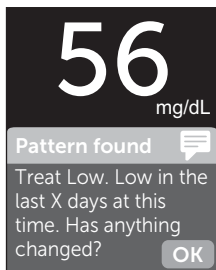

Example - Results screen with Pattern icon



Example - Pattern Message

To view the details about the individual blood glucose results that resulted in the Pattern, press  again.

Low Pattern		
mg/dL		
<b>Jun 11</b> <b>12:05 am</b>		<b>56</b>
<b>Jun 09</b> <b>12:01 am</b>		<b>65</b>

**Example - Results that  
created Low Pattern**

Or you can access the Patterns using the Results Log screen. See page 102.

## 5 Understanding Messages

Low (or Hypo\*) Pattern Messages appear when any 2 results over the past 5 days are:

- within the same 3-hour period
- below your low mealtime range limits

**NOTE:** Follow your healthcare professional's advice for treating a low blood glucose result.

\*Lee-Davey, J., Alexander, S., & Raja, P. (2011, February 16). *Clinical Patterns of Low Blood Glucose Identified by a Pattern Algorithm May Predict Increased Risk of Severe Hypoglycemia in the Following 24-Hour Period* [PDF]. Inverness, Scotland: LifeScan.

High Pattern Messages appear when any 3 results over the past 5 days are:

- within the same 3-hour period
- above your high mealtime range limits
- share the same Meal tag

Event tag Pattern Messages appear when any 3 results over the past 30 days are:

- within the same 3-hour period
- above or below your mealtime range limits
- share the same Event tag

## 5 Understanding Messages

**NOTE:** To be sure that Low and High Pattern Messages appear:

- Basic Mode must be turned off and Pattern Messages must be turned on. See page 127 and page 130.
- Update the date and time if you change time zones, or if the time changes due to Daylight saving time.
- Test your blood glucose using only one OneTouch Verio Reflect™ Meter. Using multiple meters may cause you to miss Patterns.
- Tag your blood glucose results carefully.
- Test when you feel your blood glucose may be high or low.



### **CAUTION:**

- Always use your current result for immediate treatment decisions.
- **Do Not** use Pattern Messages to make immediate or significant changes to your diabetes care plan without first consulting your healthcare professional. Always consult your healthcare professional before making significant changes to your diabetes care plan.
- **Do Not** wait for Pattern Messages to treat low or high results.
- **Do Not** allow other people to use your meter or your Patterns may be affected.

## 5 Understanding Messages

### Understanding Mentor Tips

Mentor Tips let you know when your results are consistently in range, and display diabetes management information when results are trending low and high.

**NOTE:** Mentor Tips appear with current results and cannot be viewed later.

- **Unusually Low** - Current result is below the low range limit, and is at least 5 mg/dL below your lowest result over the past 14 days.
- **Morning Low** - Current result occurred in the morning and is below the low range limit.<sup>1</sup>
- **Treat Low** - Current result is below the low range limit.<sup>1, 2</sup>
- **Unusually High** - Current result is above the high range limit, and is more than 10% higher than the highest blood glucose result in the last 14 days.

- **Morning High** - Current result occurred in the morning and is above the high range limit.<sup>1</sup>
- **Bedtime High** - Current result occurred at night and is above the high range limit.<sup>1</sup>
- **Congratulations** - Your 90-day average is improving.
- **Trend 90 Rise** - Your 90-day average has increased.
- **Trend 90 Update** - New 90-day average is available.
- **Near Low** - Result is in range but close to low range limit.
- **Near High** - Result is in range but close to high range limit.
- **Well Done** - Result is back in range after a series of either 2 low or 3 high results.
- **Keep It Up** - More than 70% of results over the past 7 days were in range.
- **Weekly Average** - New 7-day average is shown.

## 5 Understanding Messages

- **Device Not Paired** - Reminds you to pair the meter with a compatible wireless device.
- **Connect Device** - Reminds you to sync the meter with the App.
- **Exercise Low** - Current result is below the low range limit and received an Exercise Event tag.<sup>3,4</sup>
- **Take a Break** - Current result is above the high range limit and received a Stress Event tag.<sup>4</sup>



<sup>1</sup>Riddle, M. C., MD (Ed.). (2018). 6. Glycemic Targets: Standards of Medical Care in Diabetes 2018 [Abstract]. *Diabetes Care*, 41 (Suppl. 1), S60-61.

<sup>2</sup>American Association of Diabetes Educators. (2018). *HYPOGLYCEMIA What are the symptoms? And how should I treat it?* [Brochure]. Chicago, IL: Author.

<sup>3</sup>American Association of Diabetes Educators. (2017). *AADE7 Self-Care Behaviors, Problem Solving* [Brochure]. Chicago, IL: Author.

<sup>4</sup>Riddle, M. C., MD (Ed.). (2018). 6. Glycemic Targets, S44-45.

## Understanding Awards

The OneTouch Verio Reflect™ Meter tracks the goals outlined below. Each time you earn bronze () , silver () or gold () medal status, an Award will appear along with your in-range result. You can review your Awards later in the Summary. (See page 96.)

- **Test Goal Award** - Meet your Daily Test Goal a set number of times in total or in a row.
- **In-Range Award** - Achieve an in-range result a set number of times in a row.
- **Event Tag Award** - Event tag your result a set number of times in total.
- **Syncing Award** - Sync your meter to the OneTouch Reveal® App a set number of times in total.

## 6 Summary, Results Log and Trend 90

### Viewing the Summary

Depending on settings selected the Summary may display results by range, time of day, averages, mealtime averages, Test Tracker progress and Awards. You and your healthcare professional can reference the Summary to identify overall trends in your diabetes management.

#### **NOTE:**

- **Do Not** use result averages to make immediate treatment decisions. Result averages provide information from past results. Always consult your healthcare professional before making significant changes to your diabetes care plan.
- **Do Not** allow other people to use your meter as it may affect your averages.
- The meter calculates averages based on the 7-, 14- and 30-day periods ending on the current date setting. If you change the date setting, the averages may change too.

- The Summary screens displayed will reflect the features currently selected. See page 120 for information on turning meter features on or off.
- If Basic Mode is selected, your Summary will be limited to the 30-day Summary and Average views. See page 39 for more information about Basic Mode.
- In Averages, Pattern Messages and Awards, an **EXTREME HIGH GLUCOSE** result is always counted as 600 mg/dL, and an **EXTREME LOW GLUCOSE** result is always counted as 20 mg/dL.
- The green progress dot will move from left to right as you navigate through the summary screens.



Progress dot

- Pressing ⏪ will display the previous screen.

## 6 Summary, Results Log and Trend 90

1. From the Main Menu, press  or  to highlight Summary and press .

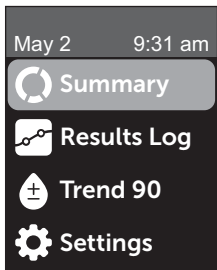

The number of results that are low (blue), in-range (green) and high (red) are displayed and appear as bar graphs.

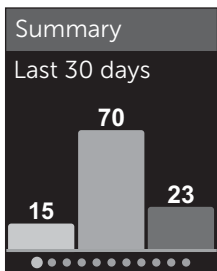

Example



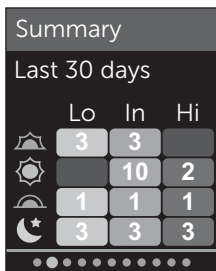

## 2. Press to display the Summary by time of day

The number of test results that are low, in-range and high, by time of day are displayed. The four time slots are Morning, Afternoon, Evening and Bedtime. The time frames for the four time slots cannot be changed.



Example

<b>Morning</b> 	6:00 am to 11:59 am
<b>Afternoon</b> 	12:00 pm to 5:59 pm
<b>Evening</b> 	6:00 pm to 11:59 pm
<b>Bedtime</b> 	12:00 am to 5:59 am

**NOTE:** If there were no results in the past 30 days in a target range and time period, that section of the chart is left blank.

## 6 Summary, Results Log and Trend 90



3. Press  to display your overall averages for the past 7, 14 and 30 days

Averages	
mg/dL	
7 Days	160
14 Days	180
30 Days	200



Example



4. If Basic Mode is off, press  to display your Before Meal averages for the past 7, 14 and 30 days

Before Meal Avg.	
mg/dL	
7 Days	 200
14 Days	 ---
30 Days	 ---



Example

5. If Basic Mode is off, press  to display your After Meal averages for the past 7, 14 and 30 days

After Meal Avg.		
mg/dL		
7 Days		160
14 Days		180
30 Days		200

Example

**NOTE:** If you do not have results in the past 7-, 14- and 30-day periods, dashes will appear in the mg/dL column.

6. If Test Tracker is on, press  to display the Daily Test Goal screens

Summary
Test Tracker

4 out of 8 test(s) completed today.

Example

## 6 Summary, Results Log and Trend 90

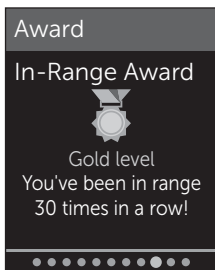
7. If Awards is on, press  to display the Award screens



Example

### Viewing the Results Log

Using the Results Log, you can review the most recent 750 results.

See page 4 for definitions of meter icons that may appear with your result.

Pressing and releasing  will allow you to view the previous screen.

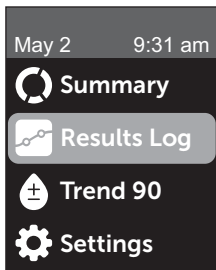

1. From the Main Menu, press  or  to highlight Results Log and press 

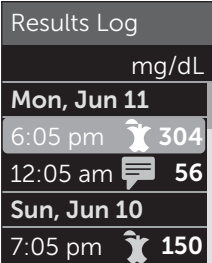

Up to four results are displayed on the screen, starting with the most recent.



A screenshot of the 'Results Log' screen. The title is 'Results Log' and the unit is 'mg/dL'. The data is organized by date. The most recent entry is for 'Mon, Jun 11', with two readings: '6:05 pm' at 304 mg/dL (with a hand icon) and '12:05 am' at 56 mg/dL (with a speech bubble icon). The next entry is for 'Sun, Jun 10', with a reading of '7:05 pm' at 150 mg/dL (with a hand icon).

Results Log		mg/dL
<b>Mon, Jun 11</b>		
6:05 pm		304
12:05 am		56
<b>Sun, Jun 10</b>		
7:05 pm		150



Example

## 6 Summary, Results Log and Trend 90

### 2. Press or to move through the list of results

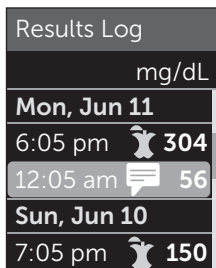
**NOTE:** If a result is part of a Pattern, the Pattern icon will be displayed for that result instead of any tags that result may have.



Results Log	
mg/dL	
<b>Mon, Jun 11</b>	
6:05 pm	 304
12:05 am	 56
<b>Sun, Jun 10</b>	
7:05 pm	 150



Example

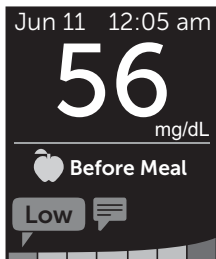

### 3. Highlight a result with an icon and press

The result screen will be displayed along with the date and time the result was taken and any tag, Pattern or Range Indicator icons. If you are uncertain whether the result you are viewing is your most current result, view the date and time on the screen.



Example

If the result is part of a Pattern, indicated by , pressing  again will display the results that led to the Pattern. See page 85 for more information about Patterns.

Low Pattern		
mg/dL		
<b>Jun 11</b>		<b>56</b>
<b>12:05 am</b>		
<b>Jun 09</b>		<b>65</b>
<b>12:01 am</b>		

Example

## Viewing the Trend 90

The OneTouch Verio Reflect™ Meter averages results over the past 90 days to provide a view of the overall trend of blood glucose results. There must be at least 90 days of results stored in the meter for the first 90-day average to appear. A point will be added to the Trend 90 graph on the screen to represent the first 90-day average. After the first 90-day average a new point is displayed every 14 days.

## 6 Summary, Results Log and Trend 90

### NOTE:

- Basic Mode must be turned off to use the Trend 90 feature. (See page 127.)
- The Trend 90 is an average of blood glucose results. Always use your current blood glucose result for immediate treatment decisions.

1. From the Main Menu, press  or  to highlight Trend 90 and press .

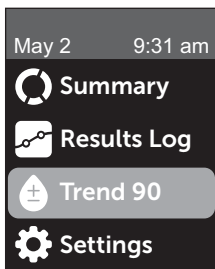



The current 90-day average will be displayed as a blood glucose value with the unit of measure.

The Trend 90 graph is automatically updated every 14 days. Each point on the graph represents a 90-day average. You can track your Trend 90 visually by following the path of points along the graph.

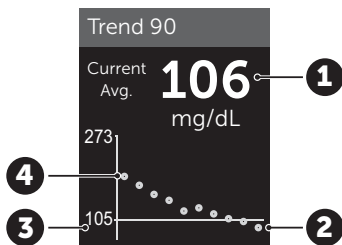

### Example

<b>1</b>	Current 90-day average
<b>2</b>	Newest average point
<b>3</b>	90 Day Average Target set in the meter
<b>4</b>	Oldest average point

**2. Press**  **to return to the Main Menu**



## 7 Syncing your meter

### Connecting to a compatible wireless device

#### Turning the BLUETOOTH® feature on or off

In order to connect your meter with your compatible wireless device, the BLUETOOTH® feature will need to be turned on. The  symbol will appear on the meter screen when the BLUETOOTH® feature is on. When the  symbol is not present on the screen the BLUETOOTH® feature is off.

#### 1. Start by turning your meter on using the button

Wait for the Main Menu to appear, then press  or  to highlight **Settings** and press 

#### 2. On the Settings Menu, highlight Bluetooth and press

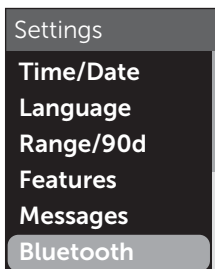

A ✓ notes if BLUETOOTH® is currently set to On or Off.

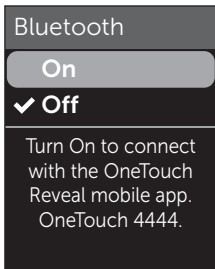

**3. Press  or  to highlight On or Off and press **

**NOTE:** The BLUETOOTH® feature will turn OFF during a blood glucose test.

## 7 Syncing your meter

### Pairing overview

Pairing allows your OneTouch Verio Reflect™ Meter to communicate with compatible wireless devices. The devices must be within 26 feet of each other to pair and sync. Download the OneTouch Reveal® Mobile App from the App Store or on Google Play before pairing your meter and compatible wireless device.



Apple and the Apple logo are trademarks of Apple Inc., registered in the U.S. and other countries. App Store is a service mark of Apple Inc., registered in the U.S. and other countries.

Google Play and the Google Play logo are trademarks of Google LLC.

Multiple OneTouch Verio Reflect™ Meters can be paired with your compatible wireless device. For example, your compatible wireless device can be paired with a meter at home and another at work. To pair multiple meters, repeat the pairing instructions for each meter. See page 112 for pairing instructions.

Your OneTouch Verio Reflect™ Meter can be paired with multiple compatible wireless devices. To pair multiple compatible wireless devices, repeat the pairing instructions for each compatible wireless device.

## 7 Syncing your meter

### Pairing instructions

The BLUETOOTH® feature must be turned on in order to pair the meter with the app. See page 108.

**1. Open the OneTouch Reveal® Mobile App and follow instructions to pair the meter with your compatible wireless device**

**2. Look for "OneTouch" and the last 4 characters of the meter serial number on the compatible wireless device display to correctly identify your meter**

The meter screen will display the pairing info to look for on your compatible wireless device.

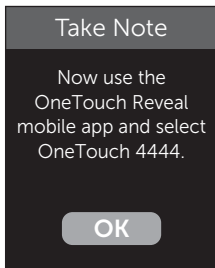

Example

**3. When prompted by the OneTouch Reveal® Mobile App, the meter will display a six digit PIN number**

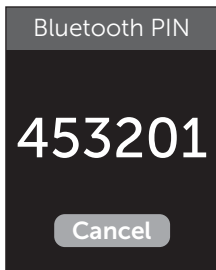

Example PIN

Enter the PIN number into your compatible wireless device using the keypad.

**⚠ CAUTION:**

Make sure the PIN you enter on your compatible wireless device matches the PIN on your meter display. If a PIN number unexpectedly appears on your meter display, cancel the PIN request by either inserting a test strip to take a test or press the **OK** button to cancel.

## 7 Syncing your meter

### 4. Wait for your compatible wireless device to indicate that it is paired with your meter

### Sending your results to the app

If the BLUETOOTH® feature on the meter is turned on, indicated by the BLUETOOTH® symbol () , the meter will automatically send your results to any paired compatible wireless device.

The Sync symbol () flashes on the meter display. After syncing, the Sync symbol will disappear and the app will display a list of any new results sent from the meter. You can then share your results with your caregiver or healthcare professional.

#### **CAUTION:**

Always use the current result on your meter for immediate treatment decisions.

**NOTE:** The compatible wireless device must have the app open and have already been paired to the meter before sending a result. See page 110.



**NOTE:** If the BLUETOOTH® feature on the meter is **turned off**, or the meter is out of range, the result is not sent to the compatible wireless device. The result is saved in the meter memory with the current date and time, and will be sent to the app the next time you sync. The sent results are also stored in the meter. To sync, the app must be open and running on your compatible wireless device.

To ensure that glucose test results are successfully sent to the app, turn on the BLUETOOTH® feature and check the following:

- The compatible wireless device and meter are both turned on, and the app is running.
- The meter is correctly paired with your compatible wireless device.
- The BLUETOOTH® feature on both devices is running (indicated by ) and the devices are within 26 feet of each other.
- The meter will attempt to transmit results up to 4 hours after a test, even if the meter appears to be off.

## 7 Syncing your meter

If you are still unable to send results to the compatible wireless device, try un-pairing and re-pairing with the device, moving the meter and compatible wireless device closer together, or relocating them from possible sources of interference. If you continue to have difficulties, please call Customer Service. Contact information for Customer Service is listed at the end of this Owner's Booklet. Please address any app issues to the app customer service department.

### **NOTE:**

- Inserting a test strip during the transmission will cancel the transfer of all results. The **Apply Blood** screen appears and you can proceed with testing.
- Keep your meter in your care to avoid inaccurate results from being sent to your compatible wireless device.

This page left blank intentionally.

## **7** Syncing your meter

### **Downloading results to a computer**

Your meter can work with diabetes management software, which provides a visual way to track key factors that affect your blood sugar. To learn more about diabetes management tools available to you, contact Customer Service. Contact information for Customer Service is listed at the end of this Owner's Booklet.

Connect only to a computer certified to UL 60950-1 .

To transfer meter data, follow the instructions provided with the diabetes management software product to download the results from the meter. You will need a standard micro USB interface cable to connect your OneTouch Verio Reflect™ Meter to a computer to download results (not included).

Once the command to start the download is sent from the computer to the meter, the **Cable Connected** screen will appear, indicating that the meter is in communication mode.

**Do Not** insert a test strip while the meter is connected to a computer.

If you are unable to download your results to a computer, please call Customer Service.

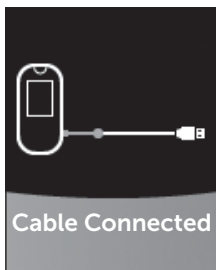

## 8 Adjusting meter settings

### Settings Menu overview

After first time setup, you can use the Settings Menu to adjust the meter settings and access additional features.

<b>Time/Date</b>	Set the time and date
<b>Language</b>	Set the language displayed on screens
<b>Range/90d</b>	<ul style="list-style-type: none"><li>• Set Before Meal limits</li><li>• Set After Meal limits</li><li>• Set the 90 Day Average Target</li></ul>
<b>Features</b>	<ul style="list-style-type: none"><li>• Turn Basic Mode on or off</li><li>• Turn Test Tracker on or off</li><li>• Set Daily Test Goal</li><li>• Set Range Indicator icon to emoji or text</li></ul>
<b>Messages</b>	<ul style="list-style-type: none"><li>• Turn Pattern Messages on or off</li><li>• Turn Mentor Tips on or off</li><li>• Turn Awards on or off</li></ul>
<b>Bluetooth</b>	Turn the BLUETOOTH® feature on or off
<b>Control Test</b>	Initiate a control solution test
<b>Meter Info</b>	View meter serial number, software version and last sub-error code

**NOTE:** For information on **Bluetooth**, see page 13. For information on **Control Test**, see page 70.

## Navigating to the Settings Menu

From the Main Menu, press  or  to highlight Settings and press .

The Settings Menu is displayed.

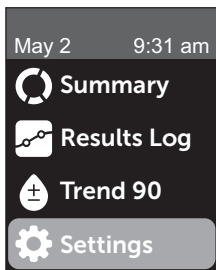





## Adjusting the time and date

You can change the time and date setting whenever needed, such as during travel.



**NOTE:** Adjusting this setting to a time and date prior to your last blood glucose or control solution test will cause the Results Log to appear out of sequence. The Results Log will display results in the order in which they were taken.

## 8 Adjusting meter settings

1. From the Settings Menu, press  or  to highlight Time/Date and press 
2. Highlight the time or date and press 
3. Adjust the desired setting and press 

Repeat this step as necessary.

## Adjusting the language

1. From the Settings Menu, press  or  to highlight Language and press 

A  appears next to the current language set in the meter.

2. Highlight the desired language, then press 

The Settings Menu will be displayed in the new language you have selected.





## Adjusting range limits and 90 Day Average Target

### **NOTE:**

- If you adjust your range limits, your previous Range Indicator icons in the Results Log will not change. Only new results will be affected by your range limit changes.
- Consult with your healthcare professional about the range limits and 90 Day Average Target that are right for you.

## 8 Adjusting meter settings

1. From the Settings Menu, press  or  to highlight **Range/90d** (or **Range for Basic Mode**) and press .

Your current meter settings are displayed.

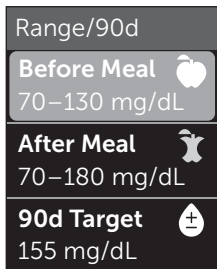

Example - Basic  
Mode Off

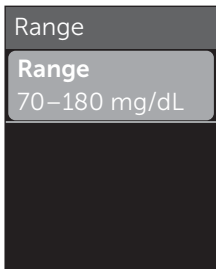

Example - Basic  
Mode On

2. Highlight the range setting to be adjusted and press .

### 3. Adjust the Low Limit and press

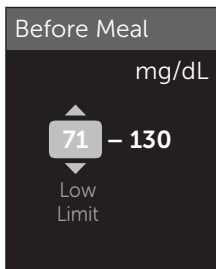

#### Example - Before Meal

Repeat this step to change the High Limit. See page 29 for information about Before and After Meal low and high limits.

**NOTE:** In Basic Mode, range limits are general and are not defined by mealtime. General range limits are pre-set.

## 8 Adjusting meter settings

### General range limits

pre-set low limit	70 mg/dL
pre-set high limit	180 mg/dL
low limit must be set within	60 mg/dL and 110 mg/dL
high limit must be set within	90 mg/dL and 300 mg/dL

4. To adjust the 90 Day Average Target, highlight the 90d Target setting and press 

5. Adjust the 90 Day Average Target and press 





The meter is pre-set with a 90 Day Average Target of 155 mg/dL. The minimum 90 Day Average Target is 99 mg/dL and the maximum is 265 mg/dL.

**NOTE:** Be sure to talk to your healthcare professional about the 90 Day Average Target that is right for you.

## Turning Basic Mode on or off

**NOTE:** Selecting Basic Mode affects the information the meter displays. See page 39 for more information.

**1. From the Settings Menu, press  or  to highlight Features and press **

The Features Menu indicates whether Basic Mode is currently on or off.

**2. Highlight Basic Mode and press **

A  appears next to the current mode set in the meter.

## 8 Adjusting meter settings

### 3. Highlight On or Off and press

In Basic Mode, Test Tracker and Range Indicator are removed from the Features Menu.

Basic Mode uses pre-set general range limits which are different from the ones set during first time setup. See page 123 for information on adjusting range limits.

## Turning the Test Tracker on or off and setting a Daily Test Goal

### 1. From the Settings Menu, press or to highlight Features and press

The Features Menu indicates the current Test Tracker setting.

**NOTE:** If Basic Mode is selected the Test Tracker will not appear in the Features Menu.

### 2. Highlight Test Tracker and press

**3. Adjust the Daily Test Goal, then press** (OK)

The meter is pre-set with a Daily Test Goal of four tests per day. The maximum Daily Test Goal is eight.

**NOTE:** Be sure to talk to your healthcare professional about the Daily Test Goal that is right for you.

To turn off the Test Tracker, press (↑) or (↓) until **Off** is highlighted, and press (OK).

**Set the Range Indicator icon to emoji or text****1. From the Settings Menu, press** (↑) or (↓) **to highlight Features and press** (OK)

Your current meter settings are displayed.

**2. Highlight Range Indicator and press** (OK)

A ✓ appears next to the current setting in the meter.



**3. Highlight Emoji or Text, then press** (OK)

### Turning Pattern Messages, Mentor Tips and Awards on or off

#### **NOTE:**

- Basic Mode must be turned off for the Messages Menu to appear in Settings. See page 127.
- If Pattern Messages are turned off, you will no longer see Patterns with results, Summary or Results Log screens. The meter will continue to track Pattern information. If you turn Pattern Messages back on again, Pattern icons will be displayed in the Summary and Results Log. See page 85 for more information about Pattern Messages.
- If Mentor Tips are turned off, you will no longer see Mentor Tips with results. See page 92 for more information about Mentor Tips.
- If Awards are turned off, you will no longer see Awards with results or in the Summary view. See page 95 for more information about Awards.



**1. From the Settings Menu, press  or  to highlight Messages and press **

Your current meter settings are displayed.

**2. Highlight Pattern, Mentor Tips or Awards and press **

A  appears next to the current setting in the meter.

**3. Highlight On or Off and press **

## **View meter info and last sub-error code**

The meter serial number, software version, and information about the last meter sub-error are stored in your meter. You can check this information at any time and use it for troubleshooting.

## 8 Adjusting meter settings

1. From the Settings Menu, press **⬆** or **⬇** to highlight **Meter Info** and press **Ⓞ**

The meter serial number, software version, and unit of measure are displayed.

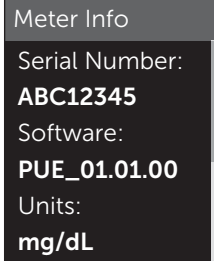

Example

2. Press **⬇** to view information about the last meter error

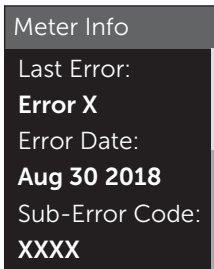

Example

Pressing **⬅** returns you to the Settings Menu.

This page left blank intentionally.

## 9 Caring for your system

### Storing your system

Once opened, store your meter, test strips, control solution and other items in your carrying case. Keep in a cool, dry place between 41°F and 86°F and below 90% relative humidity. Keep away from direct sunlight and heat. **Do Not** store the test strip vial in rooms where the air is humid such as the kitchen, laundry room or bathroom. Exposure to temperatures outside the storage limits, as well as moisture and humidity, may cause inaccurate readings.

### Cleaning and disinfection

Cleaning and disinfection are different. Both should be performed at least once per week.

Cleaning is part of your normal care and maintenance, but does not kill germs.

Disinfection is the only way to reduce your exposure to disease. After use and exposure to blood, all parts of this kit may transmit infectious diseases.

You should clean your meter, lancing device and cap before disinfecting.

For cleaning information, see page 136 and for disinfecting information, see page 137.

For cleaning and disinfecting, Clorox® Germicidal Wipes\* containing 0.55% sodium hypochlorite as the active ingredient have been shown to be safe for use with the OneTouch Verio Reflect™ System and can be obtained from retail websites offering disinfection products, e.g., [www.officedepot.com](http://www.officedepot.com) or [www.staples.com](http://www.staples.com). For more information on purchase options contact Customer Service. Contact information for Customer Service is listed at the end of this Owner's Booklet.

\*Other products, such as Clorox® Disinfecting Wipes, have not been tested and should not be used. Only Clorox® Germicidal Wipes should be used. Follow manufacturer's instruction for handling and storage of wipes. Clorox® is a registered trademark of the Clorox Company.

**IMPORTANT:** If another person assists you with testing, the meter, lancing device and cap should always be cleaned and then disinfected prior to use by that person.

## 9 Caring for your system

### Cleaning your meter, lancing device and cap

The meter, lancing device and cap should be disinfected at least once per week. Be sure to clean the meter, lancing device and cap before disinfecting.

#### To clean your meter:

**1. Use a Clorox® Germicidal Wipe to wipe the outside of the meter and lancing device (including all surfaces, test strip port, data port, seams and buttons)**

To clean your meter, hold it with the test strip port pointed down.

If the Clorox® wipe is dripping wet, be sure to squeeze out any excess liquid before you wipe the meter.

Wipe the outside of the lancing device cap.

**2. Wipe dry with a clean, sterile gauze**



## Disinfecting your meter, lancing device and cap

The meter, lancing device and cap should be disinfected at least once per week (including all surfaces, test strip port, data port, seams and buttons). Be sure to clean the meter, lancing device and cap before disinfecting.

### To disinfect your meter:

#### 1. First, clean your meter, lancing device and cap

Follow step 1 of page 136.

#### 2. Use a new Clorox® Germicidal Wipe to wipe the outside of the meter, lancing device and cap until the surface is damp

If the Clorox® wipe is dripping wet, be sure to squeeze out any excess liquid before you wipe the meter. Hold the meter with the test strip port pointed down.



Allow the surface of the meter, lancing device and cap to remain damp for 1 minute.

## 9 Caring for your system

### 3. Wipe dry with a clean, sterile gauze



Wash hands thoroughly with soap and water after handling the meter, lancing device and cap.

- **Do Not** use alcohol or any other solvent.
- **Do Not** allow liquids, dirt, dust, blood or control solution to enter the test strip port or the data port.
- **Do Not** squeeze the germicidal wipe into test strip port.
- **Do Not** spray cleaning solution on the meter and lancing device.
- **Do Not** immerse the meter and lancing device in any liquid.



The OneTouch Verio Reflect™ System withstood cleaning and disinfection cycles well in excess of LifeScan's recommendation. See page 140 for more details.

Examples of damage to the meter may include fogged display, cracked housing or lens, illegible labels, button not working or meter malfunction (such as repeated error messages). Examples of damage to the lancing device and cap may include cracking, illegible depth setting numbers and lancing device malfunction (such as failure to load, cock or release).

**Do Not** use your meter or lancing device if you see evidence of such damage. If you have questions about cleaning or disinfecting, or if you see evidence of physical damage, contact Customer Service. Contact information for Customer Service is listed at the end of this Owner's Booklet.

## **9** Caring for your system

### **Cleaning and disinfecting cycles**

The meter can be cleaned and disinfected weekly for 4 years, and has been tested up to 209 cleaning and disinfection cycles.

The meter can also be cleaned up to an additional one time per week over the 4 year use lifetime.

The lancing device and cap can be cleaned daily for 3 years and have been tested up to 2829 cleaning cycles.

The lancing device and cap can be disinfected weekly for 3 years, and have been tested up to 412 disinfection cycles.

This page left blank intentionally.

## 10 Batteries

### Replacing the batteries

Your OneTouch Verio Reflect™ Meter uses 2x CR2032 lithium batteries. One battery powers the meter only and the other powers the backlight. See page 155 for information on when to change the meter batteries.

If the meter does not turn on, or remains dim after pressing a button, check the batteries.

**Do Not** change the batteries when connected to a PC.

**⚠️ WARNING: CHEMICAL BURN HAZARD. DO NOT INGEST BATTERY.** This product contains a coin/button cell battery. If swallowed, it can quickly cause severe internal burns and can lead to death. Keep new and used batteries away from children. If you think batteries might have been swallowed, seek immediate medical attention.



**IMPORTANT:** Use only CR2032 lithium batteries with your meter. **Do Not** use rechargeable batteries. Use of an incorrect battery type or a used battery may result in your meter providing fewer tests than normal.

**⚠️ WARNING:** Certain batteries may cause leaking, which can damage the meter or cause the batteries to lose power sooner than normal. Replace leaking batteries immediately.

## 1. Remove the old batteries

Start with the meter turned off. Remove the battery cover by pressing and sliding it downward.



Pull up firmly on the plastic ribbons. The plastic ribbon with the  symbol is for the meter battery, and the plastic ribbon with the  symbol is for the backlight battery. Always change both batteries at the same time.



## 10 Batteries

### 2. Insert the new batteries

With the "+" side facing up toward you, place each battery in the compartment within the fold of the plastic ribbon.

Push each battery in until it snaps into the battery clasp.



Replace the battery cover by sliding it upwards onto the meter.

If the meter does not power on after you have replaced the batteries, check that the batteries are correctly installed with the "+" side up. If the meter still does not power on, contact Customer Service. Contact information for Customer Service is listed at the end of this Owner's Booklet.



### **3. Check your meter settings**

You will be prompted to set the time and date whenever you change the batteries. See page 121.

### **4. Dispose of batteries**

Dispose of batteries according to your local environmental regulations.

## **11** Troubleshooting

### **Error and other messages**

The OneTouch Verio Reflect™ Meter displays messages when there are problems with the test strip, with the meter or when your glucose levels are above 600 mg/dL or below 20 mg/dL. Improper use may cause an inaccurate result without producing an error message.

**NOTE:** If the meter is on but does not operate (locks up), contact Customer Service. Contact information for Customer Service is listed at the end of this Owner's Booklet.



### What it means

You may have a very low blood glucose level (severe hypoglycemia), below 20 mg/dL.

### What to do

**This may require immediate treatment.** Although this message could be due to a test error, it is safer to treat first and then do another test. Always treat according to your healthcare professional's recommendations.

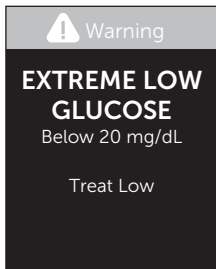

### What it means

You may have a very high blood glucose level (severe hyperglycemia), over 600 mg/dL.

### What to do

**Re-test your blood glucose level.** If the result is **EXTREME HIGH GLUCOSE** again, obtain and follow instructions from your healthcare professional right away.

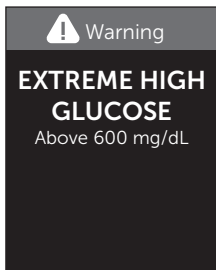

## 11 Troubleshooting

### What it means

Meter is too hot (above 111°F) to perform a test.

### What to do

Move the meter and test strips to a cooler area. Insert a new test strip when the meter and test strips are within the operating range (43-111°F). If you do not get another **Temperature too high** message, you can proceed with testing.

If this message continues to appear, contact Customer Service. Contact information for Customer Service is listed at the end of this Owner's Booklet.



#### Warning

Temperature too high.  
Out of operating  
range. See Owner's  
Booklet.

## What it means

Meter is too cold (below 43°F) to perform a test.

## What to do

Move the meter and test strips to a warmer area. Insert a new test strip when the meter and test strips are within the operating range (43-111°F). If you do not get another **Temperature too low** message, you can proceed with testing.

If this message continues to appear, contact Customer Service. Contact information for Customer Service is listed at the end of this Owner's Booklet.



### Warning

Temperature too low.  
Out of operating  
range. See Owner's  
Booklet.

## 11 Troubleshooting

### Error Screens

If there is a problem with the meter, the following error screens may appear. If you cannot resolve the error with your meter, contact Customer Service. They will refer to the error number, and a sub-error code found in the Meter Info screen, to help troubleshoot the problem. See page 131 for more information on viewing the Meter Info screen.

#### What it means

There is a problem with the meter.

#### What to do

**Do Not** use the meter. Contact Customer Service. Contact information for Customer Service is listed at the end of this Owner's Booklet.

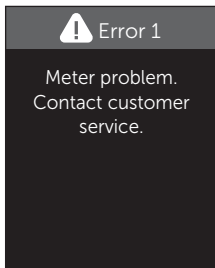

## What it means

Error message could be caused by a used test strip, applying blood to the test strip before inserting it into the meter or a problem with the meter or test strip.

## What to do

Repeat the test with a new test strip; see page 42 or page 70. If this message continues to appear, contact Customer Service. Contact information for Customer Service is listed at the end of this Owner's Booklet.



Error 2

Meter or strip problem. Retest with a new strip.

## 11 Troubleshooting

### What it means

The sample was applied before the meter was ready.

### What to do

Repeat the test with a new test strip. Apply a blood or control solution sample only after the

**Apply Blood** or **Apply Control**

**Solution** screen appears on the display. If this message continues to appear, contact Customer Service. Contact information for Customer Service is listed at the end of this Owner's Booklet.



Error 3

Meter was not ready.  
Retest with a  
new strip.

## What it means

*One of the following may apply:*

- Not enough blood or control solution was applied or more was added after the meter began to count down.
- The test strip may have been damaged or moved during testing.
- The sample was improperly applied.
- There may be a problem with the meter.

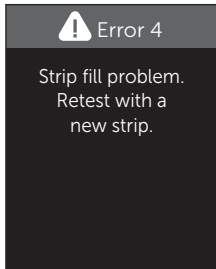

## What to do

Repeat the test with a new test strip; see page 42 or page 70. If the error message appears again, contact Customer Service. Contact information for Customer Service is listed at the end of this Owner's Booklet.

## 11 Troubleshooting

### What it means

The meter has detected a problem with the test strip. Possible cause is test strip damage.

### What to do

Repeat the test with a new test strip; see page 42 or page 70. If the error message appears again, contact Customer Service. Contact information for Customer Service is listed at the end of this Owner's Booklet.



Error 5

Strip problem. Retest with a new strip.



### What it means

Battery power is low but there is still enough battery power to perform a test. Test results will still be accurate. The flashing low battery () icon will continue to appear until the batteries are replaced.

### What to do

Press  to continue, but replace the batteries as soon as possible.

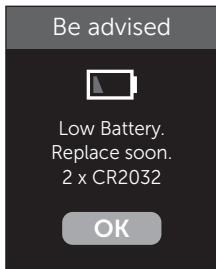

### What it means

There is not enough meter battery power to perform a test.

### What to do

Replace the batteries immediately.

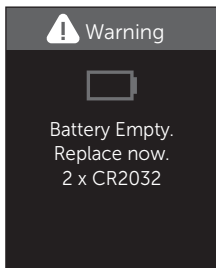

## **12** System information

### **Comparing meter results to laboratory results**

Results obtained from the OneTouch Verio Reflect™ Meter and laboratory tests are reported in plasma-equivalent units. However, your meter result may differ from your lab result due to normal variation. A result from your OneTouch Verio Reflect™ Meter is considered accurate when it is within 15 mg/dL of a laboratory method when the glucose concentration is lower than 75 mg/dL and within 15% of a laboratory method when the glucose concentration is 75 mg/dL or higher.

Meter results can be affected by factors that do not affect lab results in the same way. Specific factors that may cause your meter result to vary from your lab result may include:

- You have eaten recently. This can cause a result from fingertip testing to be up to 70 mg/dL higher than a lab test using blood drawn from a vein.<sup>1</sup>
- Your hematocrit is above 60% or below 20%.
- You are severely dehydrated.

For additional information, refer to the OneTouch Verio® Test Strip Insert.

<sup>1</sup>Sacks, D.B.: "Carbohydrates." Burtis, C.A., and Ashwood E.R. (ed.), *Tietz Textbook of Clinical Chemistry*, Philadelphia: W.B. Saunders Company (1994), 959.

### Guidelines for obtaining an accurate meter to lab comparison

#### Before going to the lab:

- Perform a control solution test to make sure your meter is working properly.
- **Do Not** eat for at least 8 hours before you test your blood.
- Take your meter and testing supplies with you to the lab.

#### Testing with your OneTouch Verio Reflect™ Meter at the lab:

- Test within 15 minutes of the lab test.
- Use only a fresh, capillary blood sample from your fingertip.
- Follow all instructions in this Owner's Booklet for performing a blood glucose test.

## **Comparing your meter results to those taken from another meter**

Comparing your blood glucose test results taken with this meter to your results taken from a different meter is not recommended. Results may differ between meters and are not a useful measure of whether your meter is working properly.

## Technical specifications

<b>Assay method</b>	FAD-GDH (flavin adenine dinucleotide dependent glucose dehydrogenase)
<b>Automatic shutoff</b>	Two minutes after last action
<b>Battery ratings</b>	Two 3.0 V d.c., (2x CR2032 batteries), == 15 mA
<b>Battery type</b>	2 replaceable 3.0 Volt CR 2032 lithium batteries (or equivalent)
<b>BLUETOOTH® technology</b>	Frequency range: 2.4-2.4835 GHz Maximum power: 0.4 mW Operating Range Distance: minimum 26.25 feet (unobstructed) Operating Channels: 40 Channels Security Encryption: 128-bit AES (Advanced Encryption Standard)
<b>Calibration</b>	Plasma-equivalent

<b>Data port type</b>	Compatible with micro USB 2.0
<b>Memory</b>	750 test results
<b>Operating ranges</b>	43-111°F Relative humidity: Non-condensing 10-90% Altitude: up to 10,000 feet Hematocrit: 20 - 60%
<b>Reported result range</b>	20-600 mg/dL
<b>Sample</b>	Fresh capillary whole blood
<b>Sample volume</b>	0.4 µL
<b>Size</b>	1.69(W) x 3.97(L) x 0.61(T) inches
<b>Test time</b>	Approximately 5 seconds
<b>Unit of measure</b>	mg/dL
<b>Weight</b>	Approximately <1.87 ounces

## 12 System information

Your OneTouch Verio Reflect™ Meter result may vary slightly from your actual blood glucose value. This may be due to slight differences in technique and the natural variation in the test technology.

The chart below shows the results of a study where 354 typical users used the OneTouch Verio Reflect™ Meter to test their blood glucose level. For example, in this study, the OneTouch Verio Reflect™ Meter gave results within 15% of their true blood glucose level 351 out of 354 times.

Difference range between the true blood glucose level and the OneTouch Verio Reflect™ meter result	Within 5%	Within 10%	Within 15%	Within 20%
The percent (and number) of meter results that match true blood glucose level within X%	62.7% (222/354)	94.1% (333/354)	99.2% (351/354)	100% (354/354)



## Regression statistics

Samples were tested on one of three test strip lots. Results indicate that the OneTouch Verio Reflect™ System compares well with a laboratory method.

# of Subjects	# of Tests	Slope	Intercept (mg/dL)
354	354	1.02	-2.66

95% CI Slope	95% CI Intercept (mg/dL)	Std. Error ( $S_{y,x}$ ) (mg/dL)	R <sup>2</sup>
1.01 to 1.04	-5.40 to 0.09	10.58	0.98

## 12 System information

### Precision

Within Run Precision (300 Venous Blood Tests per glucose level)

Target Glucose (mg/dL)	Mean Glucose (mg/dL)	Standard Deviation (mg/dL)	Coefficient of Variation (%)
40	36.8	1.05	2.84
90	89.7	2.46	2.74
130	132.8	4.07	3.07
200	206.8	5.53	2.68
350	368.7	10.84	2.94

Data generated using the OneTouch Verio Reflect™ Meter show that the greatest variability observed between test strips from three strip lots when tested with blood is 1.05 mg/dL SD or less at glucose levels less than 75 mg/dL or 3.07% CV or less at glucose levels at 75 mg/dL or above.

Total Precision (600 Control Solution Tests per Glucose Level)

Data generated using the OneTouch Verio Reflect™ Meter.

<b>Glucose Level Ranges (mg/dL)</b>	<b>Mean Glucose (mg/dL)</b>	<b>Standard Deviation (mg/dL)</b>	<b>Coefficient of Variation (%)</b>
30-50	37.74	0.93	2.47
51-110	69.00	1.40	2.02
111-150	118.65	2.24	1.89
151-250	200.53	3.70	1.84
251-400	346.74	7.66	2.21

### **Guarantee**

LifeScan guarantees that the OneTouch Verio Reflect™ Meter will be free of defects in material and workmanship for three years, valid from the date of purchase. The guarantee extends only to the original purchaser and is not transferable. If the meter stops working or a defect occurs on any part, contact Customer Service. Contact information for Customer Service is listed at the end of this Owner's Booklet.

## Electrical and safety standards

This meter complies with CISPR 11:Class B (Radiated Only). Emissions of the energy used are low and not likely to cause interference in nearby electronic equipment. The meter has been tested for immunity to electrostatic discharge as specified in IEC 61326-2-6. This meter complies with immunity to radio frequency interference as specified in IEC 61326-1 and 61326-2-6.

The meter meets the requirements for immunity to electrical interference at the frequency range and test level specified in international standard EN 60601-1-2:2014.

**Do Not** use the equipment where aerosol sprays are being used, or when oxygen is being administered.

## 13 Index

90 Day Average Target.....	38, 123
After Meal range limits.....	36, 123
After Meal tag .....	78
AST.....	47
Awards .....	25, 84, 95, 130
Basic Mode.....	39, 127
Batteries, replacing .....	142
Battery low icon.....	7, 155
Before Meal range limits .....	35, 123
Before Meal tag .....	78
Blood Sugar Mentor™ Messages.....	25, 84
BLUETOOTH® .....	13, 16, 108, 114
Buttons on meter.....	23
Cleaning your meter, lancing device and cap.....	136
Color Bar .....	27, 59
ColorSure® Dynamic Range Indicator .....	27, 35, 59, 61
Comparing meter results to laboratory results.....	156
Control solution.....	70
Control solution, discard and expiration dates.....	69
Control solution, testing .....	68, 74, 76
Daily Test Goal setting .....	37, 128
Data port .....	23
Date setting.....	33
Dehydration.....	63, 157

Disinfecting your meter, lancing device and cap.....	137
Display check .....	28
Disposal, lancets and test strips.....	68
Downloading results to a computer .....	118
Emoji .....	129
Error messages.....	146, 147
Event tagging.....	78
EXTREME HIGH GLUCOSE message.....	64, 147
EXTREME LOW GLUCOSE message .....	63, 147
Features .....	128, 129
Fingertip testing procedure .....	42
First time setup.....	29
General range limits.....	126
Guarantee.....	166
Hyperglycemia .....	64, 147
Hypoglycemia .....	63, 147
Icons.....	4, 8
Infection, reduce the chance .....	48
Intended use .....	10
Kit components.....	18
Lancet .....	46, 49
Lancet, expiration date.....	48
Lancing device .....	18, 46, 49, 136
Language.....	31, 122

## 13 Index

Meal tagging .....	78
Mealtime range limits .....	34, 35, 36
Mentor Tips .....	25, 84, 92, 130
Messages .....	85, 130
mg/dL .....	23, 161
Pairing .....	110, 112
Pattern Messages .....	25, 84, 85, 130
Patterns .....	85, 86
PIN .....	113
Plasma calibration .....	156, 160
Range Indicator icon .....	4, 7, 23, 40, 59, 61, 80, 104, 120, 123, 128, 129
Range limits .....	123
Serial number .....	131
Settings .....	29, 120, 121, 122, 123, 127, 128, 129, 130
Settings Menu .....	121
Software, diabetes management .....	118
Software version .....	131
Storing your system .....	134
Sub-error code .....	131
Summary .....	96, 102
Symbols .....	4, 8
Syncing .....	114
Technical specifications .....	160



Temperature .....	42, 43, 76, 134, 148, 149, 161
Test principle .....	12
Test strip .....	25, 52, 70
Test strip, applying drop of blood .....	55
Test strip, discard and expiration dates .....	44
Test strip, silver prongs .....	25
Test Tracker .....	27, 37, 61, 128
Time setting .....	121
Trend 90 .....	27, 105
Turning meter off .....	40
Turning meter on .....	28, 52, 70
Unexpected results .....	62, 65
Unit of measure .....	23, 161
Unusual red blood cell count (hematocrit) .....	157, 161
Welcome screen .....	28

## Notes

---

---

---

---

---

---

---

---

---

---

---



Contents covered by one or more of the following U.S. patents: 6,193,873, 6,716,577, 6,749,887, 6,797,150, 6,863,801, 6,872,298, 7,045,046, 7,498,132, 7,846,312, 8,449,740, and 8,529,751. Use of the monitoring device included herein is protected under one or more of the following U.S. patents: 6,193,873, 6,475,372, 6,797,150, 7,498,132, and 8,449,740. Purchase of this device does not act to grant a use license under these patents. Such a license is granted only when the device is used with OneTouch Verio® Test Strip. No test strip supplier other than LifeScan, Inc. is authorized to grant such a license. The accuracy of results generated with LifeScan meters using test strips manufactured by anyone other than LifeScan has not been evaluated by LifeScan.

As your partner in diabetes care, we welcome you to contact us (7 days a week, 8:00 AM - 8:00 PM Eastern Time) at 1 888 567-3003 (English), 1 888 567-3010 (Español), or [www.OneTouch.com](http://www.OneTouch.com).

Manufactured by:  
LifeScan Europe GmbH  
Gubelstrasse 34  
6300 Zug  
Switzerland

Meter Made in China  
AW 07201101A  
© 2018–2020 LifeScan IP Holdings, LLC  
Rev. Date: 01/2020

**Lifescan** 



AW 07201101A